

FLOATING BALL VALVE PN10



Size : DN 1/2" to 2"
Ends : Male BSP
Min Temperature : 0 °C
Max Temperature : + 40°C
Max Pressure : 10 Bars
Specifications : With tuning compensator (except 491 DN 1/2")
Horizontal position
Brass male valve threaded BSP

Materials : Copper or polyethylene ball

FLOATING BALL VALVE PN10

SPECIFICATIONS :

- With tuning compensator (except Ref. 491 DN 1/2"), avoid vibrations and chocks
- Horizontal position
- Brass male valve threaded BSP
- Copper or polyethylene ball
- Stainless steel needle and seat

USE :

- Water distribution and watering
- Min and max Temperature Ts : 0°C to + 40°C
- Max Pressure PN : 10 Bars
- Check the floating ball valve can move correctly after installation
- Do not cut the compensator

HEAD LOSS GRAPH (L / h) :

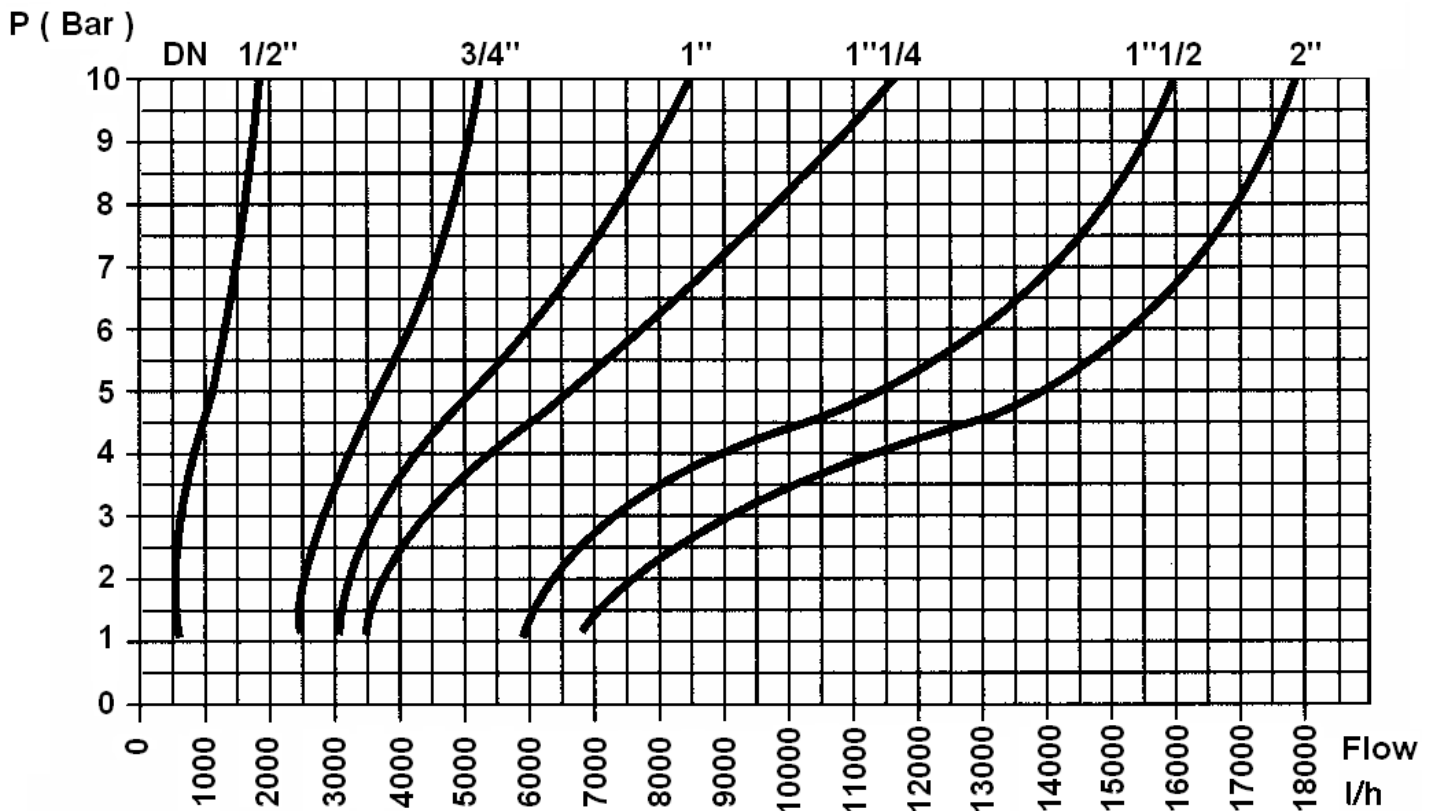

FLOATING BALL VALVE PN10

RANGE :

- Brass valve with polyethylene ball **Ref. 490** from DN 1/2" to DN 2"
- Brass valve with copper ball **Ref.491** from DN 1/2" to DN 2"

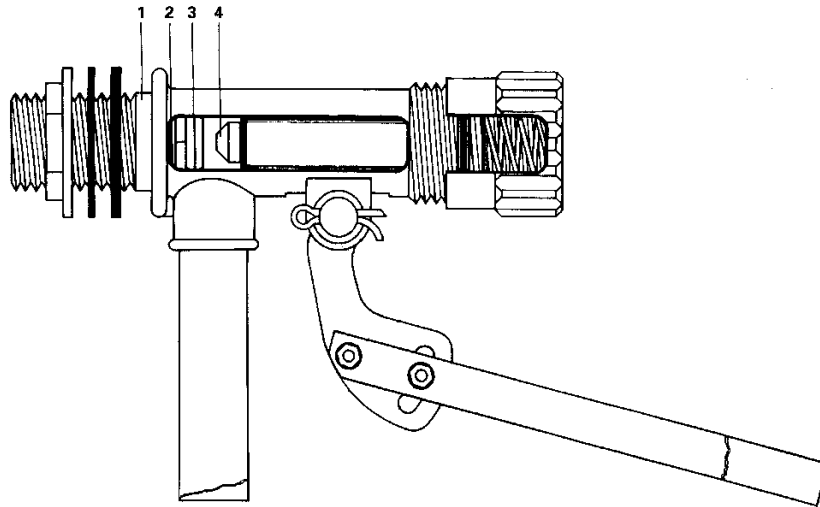
MATERIALS:

Item	Designation	Materials 490	Materials 491
1	Body	Brass	Brass
2	Gasket	EPDM	EPDM
3	Seat	Stainless steel	Stainless steel
4	Needle	Stainless steel	Stainless steel
	Ball	Polyethylene	Copper

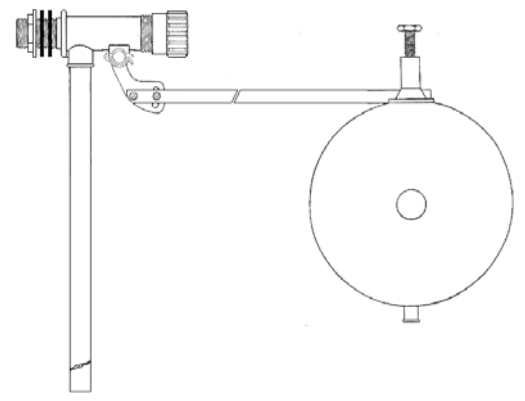
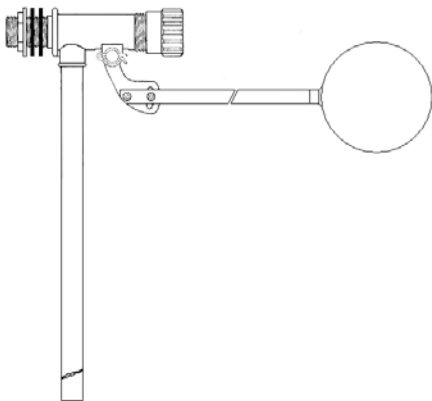
REF. 491 DN 1/2"
REF. 491 DN 3/4" - 2" AND REF. 490 DN 1/2" - 2"

FLOATING BALL VALVE PN10

SIZE (in mm) :

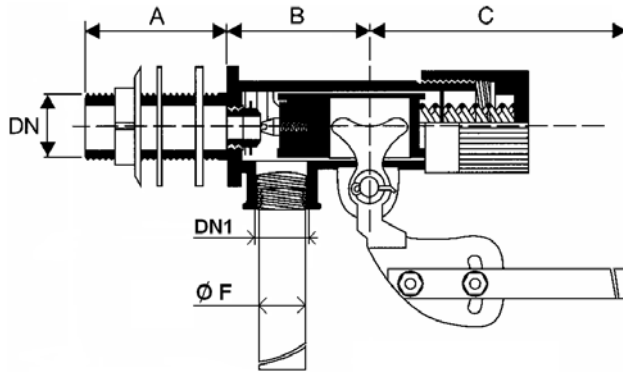

Compensator :

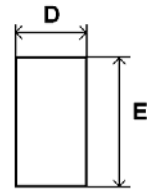

**OPENED
VALVE**

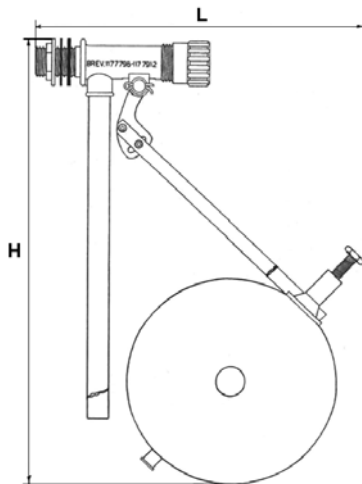

**CLOSED
VALVE**

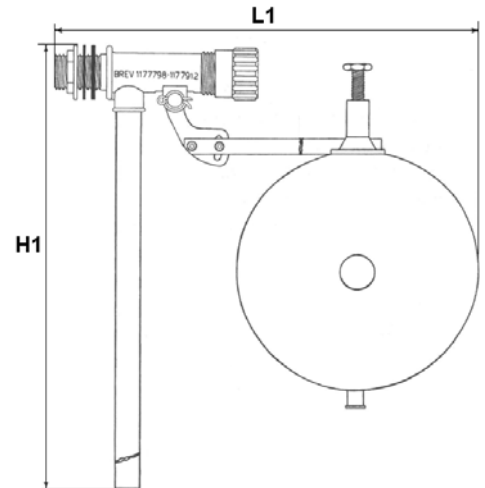

REF.	DN	1/2"	1/2"	3/4"	1"	1"1/4"	1"1/2"	2"
490/491	DN1	3/8"	3/8"	1/2"	1/2"	3/4"	1"	1"1/4"
	L	340	330	490	510	640	660	810
	L1	400	390	640	670	680	810	960
	H	340	330	510	560	560	610	710
	H1	230	230	440	460	460	570	600
	A	34	34	42	50	50	54	70
	B	27	27	53	53	58	60	77
	C	285	285	508	508	510	630	631
	D	3.5	3.5	4	4	4	5	5
	E	8	8	15	15	15	16	16
490	Ø Ball	120	-	150	180	220	220	300
491	Ø Ball	-	100	150	180	220	220	300
490/491	Weight (Kg)	0.37	0.37	1.16	1.36	1.91	2.65	5.38

FLOATING BALL VALVE PN10

STANDARDS :

- Fabrication according to ISO 9001 : 2000
- DIRECTIVE 97/23/CE : Products excluded from directive (Article 1, § 3.2)
- French water agreement **A.C.S. N° 11 ACC NY 105** for Ref. 491 and for valve of the Ref. 490 (the polyethylene ball has not A.C.S.)

ADVICE : Our opinion and our advice are not guaranteed and SFERACO shall not be liable for the consequences of damages. The customer must check the right choice of the products with the real service conditions.

INSTALLATION INSTRUCTIONS

GENERAL GUIDELINES :

- Ensure that the valves to be used are appropriate for the conditions of the installation (type of fluid, pressure and temperature).
- Ensure that the valves installed according to actual norms.
- Ensure there are no external articles which could perturb the functioning of the valve. The compensator must move freely
- When installing with outside opened tank, ensure that no external articles could perturb the functioning of the valve or block the compensator.

INSTALLATION INSTRUCTIONS :

- **Before installing the valves, clean and remove any objects from the pipes** (in particular bits of sealing and metal) which could obstruct and block the valves.
- When installing with outside opened tank, provide a protection for the ball and the compensator to avoid problems with external articles. This protection should be opened at the top and at its bottom so that it doesn't involve the reel high of the fluid. The protection height should be at least equal to the compensator movement height. The compensator and the ball must not touch the protection.
- The compensator must not be cutted.
- To avoid a blocking of the compensator, a regular check is necessary.